



KSX

PREMIUM CLASS TIPPERS FOR ALL YOUR TRANSPORT



Ansems TIPPERS KSX

LOW LOADER TRAILERS



FLATBED TRAILERS



MULTIPURPOSE TRAILERS



CAR TRANSPORTERS



TIPPERS



HARD TOP COVER TRAILERS



BOX VAN TRAILERS



HORSE TRAILERS



CONSTRUCTION TRAILERS



**“THE ANSSEMS KSX
IS A REAL
POWERHOUSES”**

KSX - Tipper with class

With its three-way tipping facility, a tipping angle of 45° and its robust build quality, the Anssems KSX is a great tool for professionals. The KSX tipper has a robot welded chassis and heavy duty 145 cm long A-frame allowing great support while maintaining much needed carrying capacity. The upper chassis is made of robot welded steel creating a strong loading floor support. The entire range is 100% wood-free guarantying years of trouble free use.



Anssems has paid attention to every detail

The built-in battery and battery charger give you peace of mind. You can always rely on the remote control tipping function. The remote control is much safer and is giving you all round visibility while unloading compared to the manual tipper. The KSX has a safety support under the body, a warning signal during lowering, side marker lights and integrated number plate holders. With a wide selection of accessories helping to make the KSX a market leader in its class.



Robust floor support



8 fixed tie hooks on the steel floor



Standard equipped with integrated ramp holders



Equipped with span lockers



Remote control

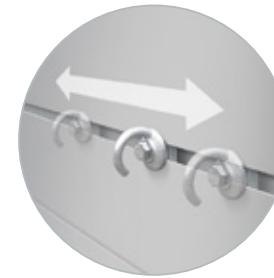

Tie rail for removable net hooks



Foldable side panels rotate under the loading floor (loading / unloading without damage)

Premium quality brake system

Remote control

Manual operation on KSX 2500 H

Robust robot welded chassis

Equipped with spanlockers

Integrated rails

Steel floor with maximum support

Fully foldable sides

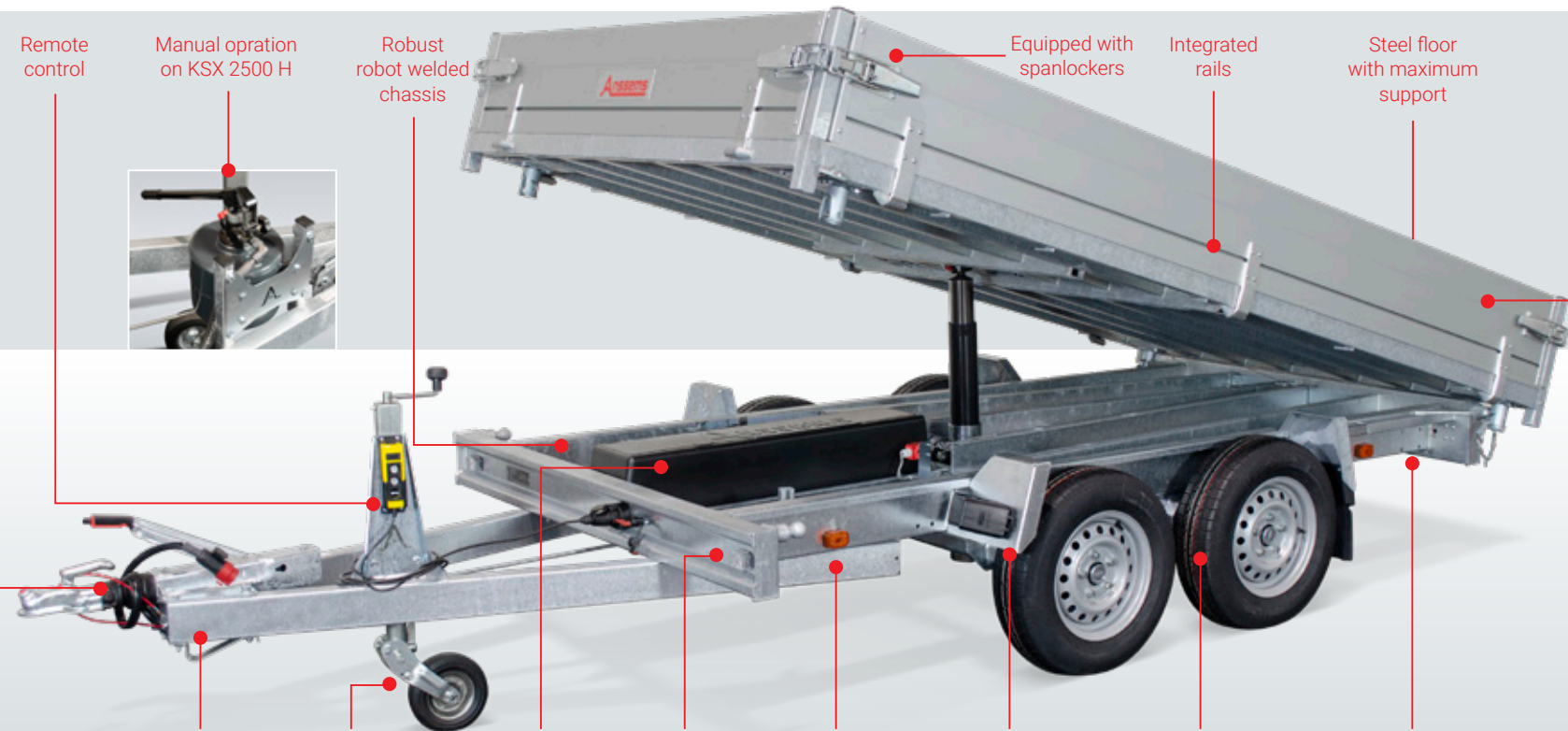

Long A-frame made out of tubular steel profiles

Automatic jockey wheel

Protective cover over battery

Marker lights

Side marker lights

Steel mudguards

Premium quality axles and wheels

Fixing holes for propstand



**“MY ANSSEMS KSX
DOES A FANTASTIC JOB
OVER AND OVER AGAIN”**

KSX Tippers, multifunctional and sustainable

During the KSX tipper development phase the keyword was to be multifunctional. Depending on your transport needs, there are 4 different models and many accessories to choose from to meet your needs. The Anssems KSX Trailer is built for heavy loads such as sand, rubble, firewood, or garden waste.



More transport volume thanks to the extension sides, an often used accessory. A internal loading height of 65 cm is created.



Popular with many KSX users is the ladder rack. The ladder rack offers more binding options and cargo support.



Accessorie:
steel or aluminium
ramps



Accessorie:
easy to use
propstands



Accessorie: high cover
deliverable in 150 and
180 cm high



Accessorie:
net hooks
(for tie-rail)



Accessorie:
spare wheel



Accessorie:
axle shock absorbers
for extra comfort



Accessorie:
spare wheel
support



The 70 cm extension sides will create a total height of 100 cm. The KSX can handle even more types of loads.



A KSX with mesh sides of 70 cm offers lots of possibilities to transport a large variety of cargo. (Total height is 100 cm).

Questions?

Ask the local Anssems dealer for all KSX options or inform yourself on www.anssems.eu. The Anssems customer service is at your service.

Anssems

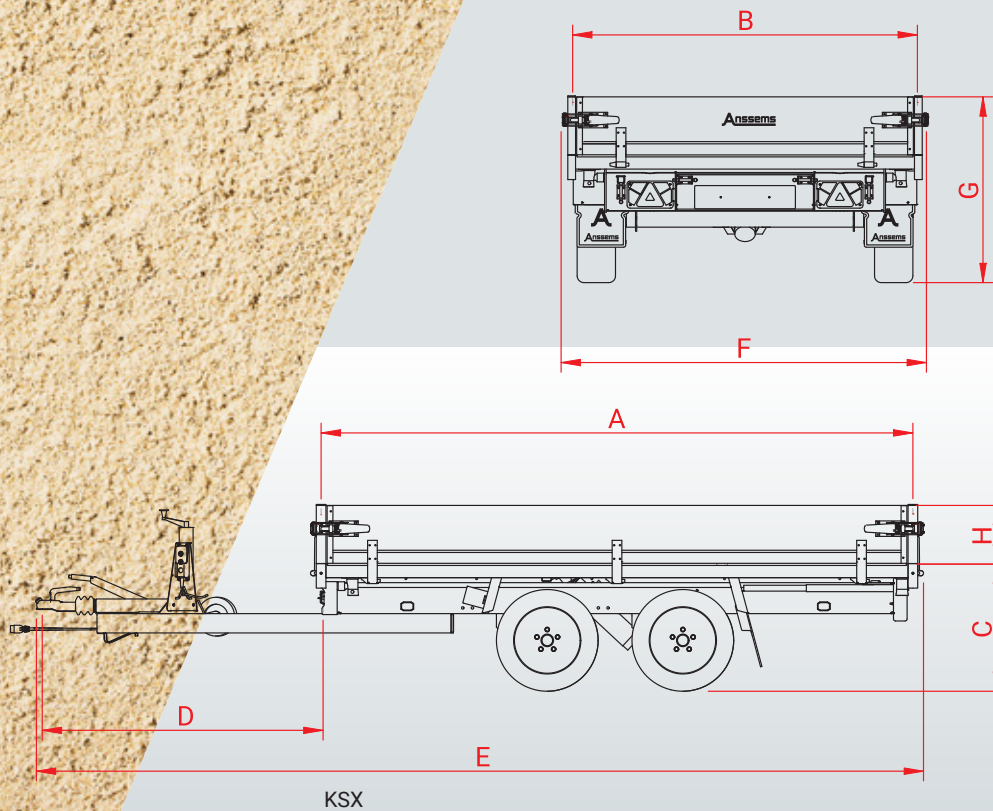

Type	KSX 2500 H 305x178	KSX 2500 E 305x178	KSX 3000 E 305x178	KSX 3500 E 305x178
Gross capacity	2500 kg	2500 kg	3000 kg	3500 kg
Unladen trailer weight	690 kg	745 kg	770 kg	820 kg
Load capacity	1810 kg	1755 kg	2230 kg	2680 kg
Axles pcs	2	2	2	2
Braked or unbraked version	braked	braked	braked	braked
Tilt control	manual	electric	electric	electric
Internal length (A)	305 cm	305 cm	305 cm	305 cm
Internal width (B)	178 cm	178 cm	178 cm	178 cm
Floor height (C)	65 cm	65 cm	63 cm	64 cm
A-Frame length (D)	145 cm	145 cm	145 cm	145 cm
Total length (E)	462 cm	462 cm	462 cm	462 cm
Total width (F)	189 cm	189 cm	189 cm	189 cm
Total height (G)	95 cm	95 cm	93 cm	94 cm
Side panel height (H)	30 cm	30 cm	30 cm	30 cm
Wheel / tyre size	185/70R13	185/70R13	185/60R12	185/60R12

Accessories	KSX 2500 H 305x178	KSX 2500 E 305x178	KSX 3000 E 305x178	KSX 3500 E 305x178
High cover (internal height 150 cm)	✓	✓	✓	✓
High cover (internal height 180 cm)	✓	✓	✓	✓
Flat cover	✓	✓	✓	✓
Extension sides (height 35 cm)	✓	✓	✓	✓
Extension sides (height 70 cm)	✓	✓	✓	✓
Propstands	✓	✓	✓	✓
Tie hooks	✓	✓	✓	✓
Tie eye M8	✓	✓	✓	✓
Aluminium Ramps	✓	✓	✓	✓
Steel Ramps	✓	✓	✓	✓
Spare wheel with support	✓	✓	✓	✓
Axle shock absorbers	✓	✓	✓	✓



**“IN MY PROFESSION
AN ANSSEMS KSX IS
INDISPENSABLE”**

Three-way tilt function

By moving the locking pins you can tilt left, right or backwards. You can easily unload your load in the right place with great precision.



Anssems

Typical Anssems

The Anssems Group has a complete program of transportation solutions for you with the brand names Anssems and Hulco. Anssems trailers has distinguished itself since 1977 by being reliable and sustainable. A generously selected standard equipment creates maximum user convenience.

Thanks to intercompany development, innovations and fully automated production processes, a high quality level is guaranteed. Anssems is one of the leading trailer producers in Europe.

Visit: www.anssems.eu



A Low loader trailers **BSX**



A Low loader trailers **GT-O / GT-R**



A Tippers **KSX**



A Tippers **KLT**



A Flatbed trailers **PSX**



A Flatbed trailers **ASX**



H Flatbed trailers **MEDAX**



A Flatbed trailers **PLT**



A Car transporters
AMT



A Car transporters
AMT



H Plant trailers
TERRAX-Basic / TERRAX



A Construction trailers **PTS**



A Multipurpose trailers
MSX



A Hard top cover trailers
GT-HT / GT-VT1



A Box van trailers
GT-VT2 / GT-VT3 / GT-VT4



A Horse trailers **PTH**

Your Anssems dealer

AB2001EN-KSX



The Anssems group

Anssems Aanhangwagens B.V.
Ericssonstraat 50
NL-5121 ML Rijen

Anssems Anhänger GmbH
Londoner Straße 15
D-48455 Bad Bentheim-Gildehaus

Anssems Remorques Sarl
Rue Pierre Brosolette
FR-58600 Garchizy

Hulco Trailers GmbH
Wiener Straße 34
D-48455 Bad Bentheim-Gildehaus